

AXE MICROPROCESS DUAL DISPLAY PANEL CONTROLLER METER MM2D Series

Features

Dual input measuring & display (DCA/DCV/ACA/ACV)	15BIT DAC analog output can be modified,0~10V /4~20mA by inside switch jumper
Accuracy 0.1% F.S. ±1 digit	RS485communication interface,Protocol MODBUS RTU MODE
Display range -19999~19999 can be modified	BAUD RATE:19200/9600/4800/2400
Decimal point can be modified	0.4" highlight display
Per input have 2 Alarm function	Man-machine interface ,easy to operate
Display average can be modified(1~99)	EEPROM Saving,data safekeeping about 10 years

Name Of Parts

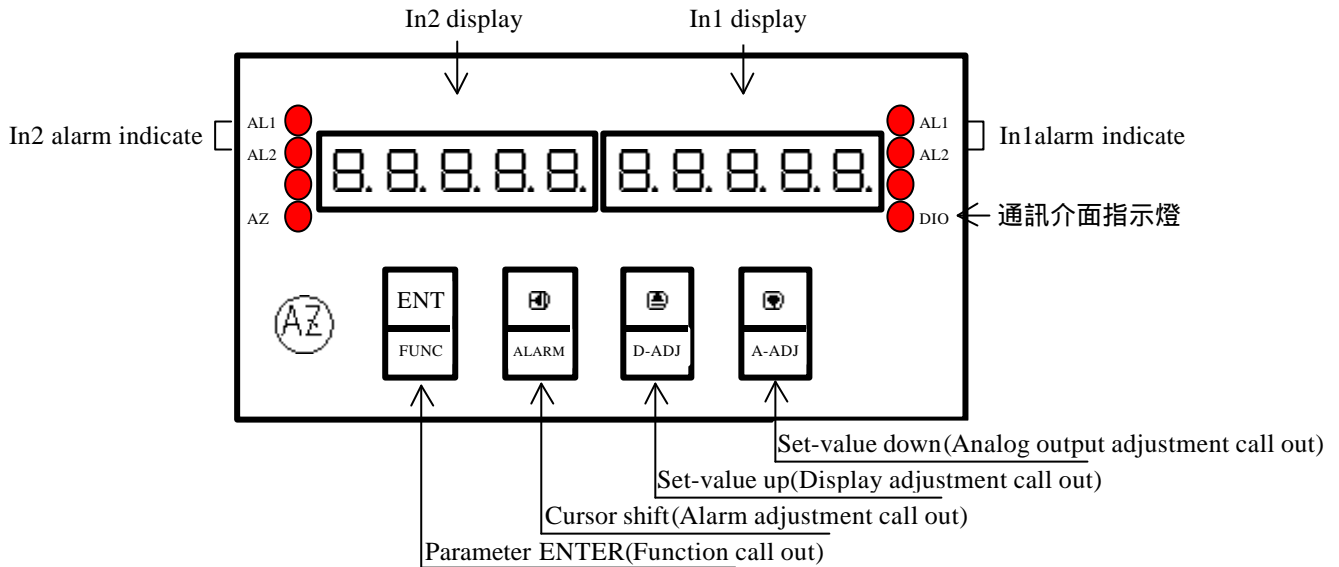

Analog Output Function Jumper Table

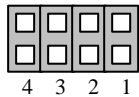

Position 1&3 ON: DC 4~20 mA OUTPUT

Position 2&4 ON: DC 0~10V OUTPUT

Key Introduce	Operation Manual
Key Function	1.In normal display,The key function is call out setting group 2.In parameter setting page,The key function is data Enter , and goto next page
Key Function	1.In normal display,The key function is call out alarm value setting page 2.Into parameter setting page,the parameter mark&data is alternate display,If need modify data can press shift key into setting procedure,The display is lock parameter data,this time must let off key about 0.2 sec,press again,the cursor(twinkle express)is cycle moving left. (Key Response about 0.2 sec)
Key Function	1.In normal display,The key function is call out adjustment display value (DZERO&DSPAN)page 2.Into parameter setting page,the parameter mark&data is alternate display,If need modify data can press up key into setting procedure,The display is lock parameter data,this time must let off key about 0.2 sec,press again,the parameter data will increment. (Key Response about 0.2 sec)
Key Function	1.In normal display,The key function is call out adjustment analog output (AZERO&ASpan)page 2.Into parameter setting page,the parameter mark&data is alternate display,If need modify data can press down key into setting procedure,The display is lock parameter data,this time must let off key about 0.2 sec,press again the parameter data will decrement. (Key Response about 0.2 sec)
& Key Function	In setting group or setting page press & key return normal display,but if in setting page the modify data will be lost
No Key in anything	In setting group or setting page no key in anything about 2 minutes,return normal display,but if in Setting page the modify data will be lost

Step	Parameter Mark Description	Parameter Mark	Operation Manual
1	Normal display	1 2 3 4 5	Press /FUNC key into P.COD setting page
2	P.COD(Pass code input page)	P.C o d	1.Key in 5 digit pass code with or or key 2.Press key,the pass code is right into setting group , otherwise return normal display
		□ □ □ □ □	
3	SYS(System setting group)	5 4 5	1. Select setting group with key 2. Press key into setting page of selection setting group
	ROP(Alarm setting group)	r o P	
	AOP(Analog output setting group)	A o P	
	DOP(Communication setting group)	d o P	
4	SYS(System setting group)	5 4 5	Press key decide SYS setting group , press key into DP1 setting page
4-1	DP1(Decimal Point 1) Default=0	d P 1	1. Decide decimal point 1 position with or key (0 to 4) 2. Press key enter data and into DSPL1 setting page
		□	
4-2	DSPL1(Display1 Low Scale) Default=0	d S P L 1	1.Decide display1 low scale with && key (-19999~19999) 2.Press key enter data and into DSPH1 setting page
		□ □ □ □ □	
4-3	DSPH1(Display1 High Scale) Default=19999	d S P H 1	1.Decide display1 high scale with && key (-19999~19999) 2.Press key enter data and into DP2 setting page
		1 9 9 9 9	
4-4	DP2(Decimal Point 2) Default=0	d P 2	3. Decide decimal point 2 position with or key (0 to 4) 4. Press key enter data and into DSPL2 setting page
		□	
4-5	DSPL2(Display2 Low Scale) Default=0	d S P L 2	1.Decide display2 low scale with && key (-19999~19999) 2.Press key enter data and into DSPH2 setting page
		□ □ □ □ □	
4-6	DSPH2(Display2 High Scale) Default=19999	d S P H 2	1.Decide display2 high scale with && key (-19999~19999) 2.Press key enter data and into AVG setting page
		1 9 9 9 9	
4-7	AVG (Average) Default=1	A v G	1.Decide display Average times with && key (1~99) 2.Press key enter data and into LCUT setting page
		□ □ □ □ □	
4-8	LCUT (Low Cut) Default=0	L C U T	1.Decide display low cut with && key (0~99) 2.Press key enter data and into CODE setting page
		□ □ □ □ □	
4-9	CODE(Pass Code) Default=0	C o d e	1.Decide Pass code with && key (0~19999) 2.Press key enter data and into LOCK setting page
		□ □ □ □ □	
4-10	LOCK(Panel Lock) Default=NO	L o c k	1.Decide panel lock with or key (NO or YES) 2.Press key enter data and into AZ.SEL setting page
		□ □	
4-11	AZ.SEL(AZ select) Default=IN12	A Z S E L	1.Decide AZ select with or key (IN12 or IN1 or IN2) 2.Press key enter data and return SYS setting group
		1 2	
5	ROP(Alarm setting group)	r o P	Press key decide ROP setting group,press key into ACT11 setting page
5-1	ACT11(IN1 Alarm Active1 setting page) Default=HI	A C T 1 1	1.Decide IN1 active 1 with or key(HI or LO) 2.Press key enter data and into ACT12 setting page
		H I	
5-2	ACT12(IN1 Alarm Active2 setting page) Default=HI	A C T 1 2	1.Decide IN1 active 2 with or key(HI or LO) 2.Press key enter data and into ACT21 setting page
		H I	
5-3	ACT21(IN2 Alarm Active1 setting page) Default=HI	A C T 2 1	1.Decide IN2 active 1 with or key(HI or LO) 2.Press key enter data and into ACT22 setting page
		H I	
5-4	ACT22(IN2 Alarm Active2 setting page) Default=HI	A C T 2 2	1.Decide IN2 active 2 with or key(HI or LO) 2.Press key enter data and into HYS11 setting page
		H I	
5-5	HYS11(IN1 Alarm Hysteresis1 setting page) Default=0	H Y S 1 1	1.Decide IN1 Hysteresis 1 with or or key(0~999) 2.Press key enter data and into HYS12 setting page
		□ □ □ □ □	
5-6	HYS12(IN1 Alarm Hysteresis2 setting page) Default=0	H Y S 1 2	1.Decide IN1 Hysteresis 2 with or or key(0~999) 2.Press key enter data and into HYS21 setting page
		□ □ □ □ □	

5-7	HYS21(IN2 Alarm Hysteresis1 setting page)Default=0	H Y S 2 1 0 0 0 0 0	1.Decide IN2 Hysteresis 1 with or or key(0~999) 2.Press key enter data and into HYS22 setting page
5-8	HYS22(IN2 Alarm Hysteresis2 setting page)Default=0	H Y S 2 2 0 0 0 0 0	1.Decide IN2 Hysteresis 2 with or or key(0~999) 2.Press key enter data and return ROP setting group
6	AOP(Analog output setting group)	R O P	Press key decide AOP setting group , press key into AO.SEL setting page
6-1	AO.SEL(Analog Output Select) Default=IN1	R O S E L I N 1	1.Decide AO.SEL with or key(IN1 or IN2 or 1ADD2 or 1SUB2 or 1MUL2 or 1DIV2) 2.Press key enter data and into ANLO setting page
6-2	ANLO(A/O Zero According to Display setting page)Default=0	A N L O 0 0 0 0 0	1.Decide ANLO with or or key(-19999~19999) 2.Press key enter data and into ANHI setting page
6-3	ANHI(A/O Span According to Display setting page)Default=0	A N H I 1 9 9 9 9	1.Decide ANHI with or or key(-19999~19999) 2.Press key enter data and return AOP setting group
7	DOP(Communication setting group)	d o p	press key decide DOP setting group,press key into ADDR setting page
7-1	ADDR(Communication – Address setting page) Default=0	A d d r 0 0 0 0 0	1.Decide address with or or key(0~255) 2.Press key enter data and into BAUD setting page
7-2	BAUD(Communication Baud Rate setting page)Value on Default=19200	b A U D 1 9 2 0 0	1.Decide baud rate with or key(19200,9600,4800,2400) 2.Press key enter data and into PARI setting page
7-3	PARI(Communication Parity Check setting page)Default=n82	P A R I n 8 2	1.Decide parity check with or key(n82,n81,even,odd) 2.Press key enter data and return DOP setting group
Step	Parameter mark description	Parameter mark	Operation manual
8	Normal display	1 2 3 4 5	Press key about 3 sec,into AL11 setting page
8-1	AL11 (IN1 Alarm value 1 setting page) Default=0	A L 1 1 0 0 0 0 0	1.Decide IN1 alarm value 1 with or or key(+/-19999) 2.Press key enter data and into AL12 setting page
8-2	AL12 (IN1 Alarm value 2 setting page) Default=0	A L 1 2 0 0 0 0 0	1.Decide IN1 alarm value 2 with or or key(+/-19999) 2.Press key enter data and into AL21 setting page
8-3	AL21 (IN2 Alarm value 1 setting page) Default=0	A L 2 1 0 0 0 0 0	1.Decide IN2 alarm value 1 with or or key(+/-19999) 2.Press key enter data and into AL22 setting page
8-4	AL22 (IN2 Alarm value 2 setting page) Default=0	A L 2 2 0 0 0 0 0	1.Decide IN2 alarm value 2 with or or key(+/-19999) 2.Press key enter data and return normal display
Step	Parameter mark description	Parameter mark	Operation manual
9	Normal display	1 2 3 4 5	Press key about 3 sec,into DZER1 adjustment page
9-1	DZER1(IN1 Display Zero Adjust)預設值為 0	d Z E R 1 0 0 0 0 0	1.IN1 Adjustment display zero with or key 2.Press key enter data and into DSPA1 adjustment page
9-2	DSPA1(IN1 Display Span Adjust)預設值為 0	d S P A 1 0 0 0 0 0	1.IN1 Adjustment display span with or key 2.Press key enter data and into DZER2 adjustment page
9-3	DZER2(IN2 Display Zero Adjust)預設值為 0	d Z E R 2 0 0 0 0 0	1.IN2 Adjustment display zero with or key 2.Press key enter data and into DSPA2 adjustment page
9-4	DSPA2(IN2 Display Span Adjust)預設值為 0	d S P A 2 0 0 0 0 0	1.IN2 Adjustment display span with or key 2.Press key enter data and return normal display
Step	Parameter mark description	Parameter mark	Operation manual
10	Normal display	1 2 3 4 5	Press key about 3 sec,into AZERO adjustment page
10-1	AZERO(Analog Output Zero Adjustment page) Value on EEPROM reset=0	A Z E R 0 0 0 0 0 0	1.Adjustment analog output zero with or or key(±9999) 2.Press key enter data and into ASPAN adjustment page

10-2	ASpan(Analog Output Span Adjustment page) Value on EEPROM reset=0	R S P R \square $\square \square \square \square \square$	1.Adjustment analog output span with \square or \square or \square key(\pm 9999) 2.Press \square key enter data and return normal display
Appendix	Error Mark Description	Error Mark	Analyze & Description
1	Input over error detect	┆ \square F L	Input signal over range(120%)
2	Input under error detect	-┆ \square F L	Input signal under range(-20%)
3	Display over error detect	\square \square F L	Display over range(19999)
4	Display under error detect	- \square \square F L	Display under range(-19999)
5	A/D Converter error detect	R d E r	1. Input signal over range (180%) 2. Inside circuit damage Please moving input signal if still display ADER,please contact us
6	EEPROM error detect	E - $\square \square$ $\square \square$ H E S	1.External interference when EEPROM read/write 2.EEPROM write over 100 million times(guarantee 10 years) Please power reset,if still display E-00,doing following step: 1.E-00 & No alternate display for inquire reset EEPROM 2. Decide Yes with \square or \square key,press \square key return normal display 3.EEPROM was reset,Please follow step 1~10 set again

MM2D Modbus RTU Mode Protocol Address Map

Data format 16/32Bit, sign bit 8000-7FFF(-32768-32767)/80000000~7FFFFFFF(-2147483648~2147483647)

Address	Name	Description	Accept
0000	DSPL1	DSPL1, input range B1E1~4E1F(-19999~19999)	R/W
0002	DSPH1	DSPH1, input range B1E1~4E1F(-19999~19999)	R/W
0004	DSPL2	DSPL2, input range B1E1~4E1F(-19999~19999)	R/W
0006	DSPH2	DSPH2, input range B1E1~4E1F(-19999~19999)	R/W
0008	AVG	AVG, input range 0001~0063(1~99)	R/W
000A	LCUT	LCUT, input range 0000~0063(0~99)	R/W
000C	CODE	CODE, input range 0000~4E1F(0~19999)	R/W
000E	HYS11	HYS11, input range 0000~03E7(0~999)	R/W
0010	HYS12	HYS12, input range 0000~03E7(0~999)	R/W
0012	HYS21	HYS21, input range 0000~03E7(0~999)	R/W
0014	HYS22	HYS22, input range 0000~03E7(0~999)	R/W
0016	AL11	AL11, input range B1E1~4E1F(-19999~19999)	R/W
0018	AL12	AL12, input range B1E1~4E1F(-19999~19999)	R/W
001A	AL21	AL21, input range B1E1~4E1F(-19999~19999)	R/W
001C	AL22	AL22, input range B1E1~4E1F(-19999~19999)	R/W
001E	A0.SEL	A0.SEL, input range 0000~0001(0~1)0:IN1,1:IN2	R/W
0020	ANLO	ANLO, input range B1E1~4E1F(-19999~19999)	R/W
0022	ANHI	ANHI, input range B1E1~4E1F(-19999~19999)	R/W
0024	AZERO	AZERO, input range D8F1~270F(-9999~9999)	R/W
0026	ASPAN	ASPAN, input range D8F1~270F(-9999~9999)	R/W
0028	ADDR	ADDR, input range 0000~00FF(0~255)	R/W
002A	BAUD	BAUD, input range 0000~0003(0~3)0:19200,1:9600,2:4800,3:2400	R/W
002C	PARI	PARI, input range 0000~0003(0~3)0:N82,1:N81,2:EVEN,3:ODD	R/W
002E	INLO1	INLO1, input range 029F16~4EA4A8(171798~5153960)	R/W
0032	INH11	INH11, input range 029F16~4EA4A8(171798~5153960)	R/W
0036	INLO2	INLO2, input range 029F16~4EA4A8(171798~5153960)	R/W
003A	INH12	INH12, input range 029F16~4EA4A8(171798~5153960)	R/W
003E	DP	MSB=DP1,LSB=DP2 per BYTE input range 0~4 0:10 ⁰ ,1:10 ¹ ,2:10 ² ,3:10 ³ ,4:10 ⁴	R/W
0040	STATUS	MSB BIT7:LOCK(1:YES 0:NO),BIT6:AZ(1:ON,0:OFF)BIT1&BIT0:AZSEL(00:IN12,01:IN1,10:IN2) LSB BIT0:ACT11,BIT1:ACT12,BIT2:ACT21,BIT3:ACT22(0:HI,1:LO)	R/W
0042	AZ1	IN1 AZ value, range B1E1~4E1F(-19999~19999)	R
0044	AZ2	IN2 AZ value, range B1E1~4E1F(-19999~19999)	R
0046	DISP1	IN1 display value, range B1E1~4E1F(-19999~19999)	R
0048	DISP2	IN2 display value, range B1E1~4E1F(-19999~19999)	R